 <p>pucc P2P Universal Computing Consortium</p>		Page1 (75)
<i>PUCC Device and Service Metadata Template</i>		

PUCC Device and Service Metadata Template
(Version 3.1 – October 17, 2020)

Peer-to-Peer Universal Computing Consortium (PUCC)

Intellectual Property Notice

©Copyright PUCC 2009. Confidential – Disclosure to PUCC members only. The information contained in this work is confidential and must not be reproduced, disclosed to non-PUCC-members without the prior written permission of PUCC, or used except as expressly authorized in writing by PUCC

Table of Content

1. Introduction.....	4
2. Terminology	4
2.1. Definitions	4
3. References.....	5
4. Goals and Requirements	5
4.1. Goals	5
4.2. Requirements	5
4.2.1. Generality	5
4.2.2. Interoperability	5
5. Service/Device Metadata Definition.....	6
5.1. Metadata Model.....	6
5.2. Metadata Definition and XML Description	8
5.2.1. Device Metadata Definition	8
5.2.2. Service Metadata Definition	23
5.2.3. Composite Service Metadata Definition	28
5.2.4. Data Type	28
6. Event Generation Condition Expression (ConditionExpression)	31
6.1. Description Method of Event Generation Condition.....	31
6.2. Condition Expression	31
6.2.1. Comparison of State Variables and Certain Values.....	31
6.2.2. Reserved Word Used for Condition Expression	31
6.2.3. Functions Described in Condition Expression	32
6.2.4. Operator Used for Condition Expression	32
6.2.5. Time, Period	32
6.2.6. Multiple Usages of Condition Expression.....	33
6.3. Example of Description of Condition Expression.....	34
Appendix A. Version History	35
Appendix B. Metadata description guideline of virtual device for collectively controlling devices	36
B.1. Outline	36
B.2. Model.....	36
B.3. Guideline of metadata definition of virtual device	39
B.4. Example of description of metadata of the virtual device	43

PUCC Device and Service Metadata Template

Appendix C. Description guideline of state variable units51

Appendix D. Description guideline of ACL(Access Control List)52

 D.1. Baseline.....52

 D.2. Access Control Target and Permission54

 D.3. Specifying Access Control55

 D.4. Access Control List.....57

Appendix E. Description guideline of Actions60

Appendix E. Metadata Schema68

PUCC Device and Service Metadata Template

1. Introduction

The widespread deployment of inexpensive communications technology, computational resources in the peer-to-peer networking infrastructure, and network-enabled end devices poses an interesting problem for end users: how to locate a particular network service or device out of hundreds of thousands of accessible services and devices. Another issue for services and devices location and discovery is how to describe the services and devices to encode such factors as cost, performance, location, and sub-device or service-specific capabilities.

This document intends to provide a template for describing devices or services in the peer-to-peer network environment.

2. Terminology

2.1. Definitions

The following terms are defined in PUCC Device Discovery and Service Invocation Protocol Specification.

- Service;
- Device;

The following terms are defined in PUCC Architecture Specification.

- PUCC Core Protocol;
- Node;
- Community;
- Community ID;

3. References

- PUCC architecture specification Version 1.0,
- PUCC protocols specification Version 1.0
- PUCC Device Discovery and Service Invocation Protocol Specification 1.0
- “Extensible Markup Language (XML) 1.0 (Second Edition)”, W3C Recommendation 6 October 2000, T. Bray et al. URL: <http://www.w3.org/TR/2000/REC-xml-20001006>
- “Hypertext Transfer Protocol -- HTTP/1.1”, RFC2616, R. Fielding et al., June 1999. URL:<http://www.ietf.org/rfc/rfc2616.txt>
- “UPnP Device Architecture v1.0.1 draft”
URL: <http://www.upnp.org>
- “UUIDs and GUIDs”, Internet Draft, Paul J. Leach et al, August 1998.
- “Universal Resource Identifier”
URL: <http://www.w3.org/Addressing/>
- “Document Type Definition”
URL: <http://www.w3.org/TR/REC-xml#dt-doctype>
- “XML Schema Part 2: Datatypes”
URL: <http://www.w3.org/TR/xmlschema-2/>

4. Goals and Requirements

4.1. Goals

The goals of this specification are:

- ◆ To define device and service metadata template for describing various devices and services
- ◆ To leverage existing standards where possible, especially existing and evolving Internet standards.

4.2. Requirements

4.2.1. Generality

The metadata description must be independent of particular devices or services.

4.2.2. Interoperability

The metadata supports for interoperability with other existing protocols such as UPnP.

5. Service/Device Metadata Definition

5.1. Metadata Model

Service/Device metadata is defined to describe services of devices and primitive devices for device discovery and execution. Following figure shows the metadata model of devices.

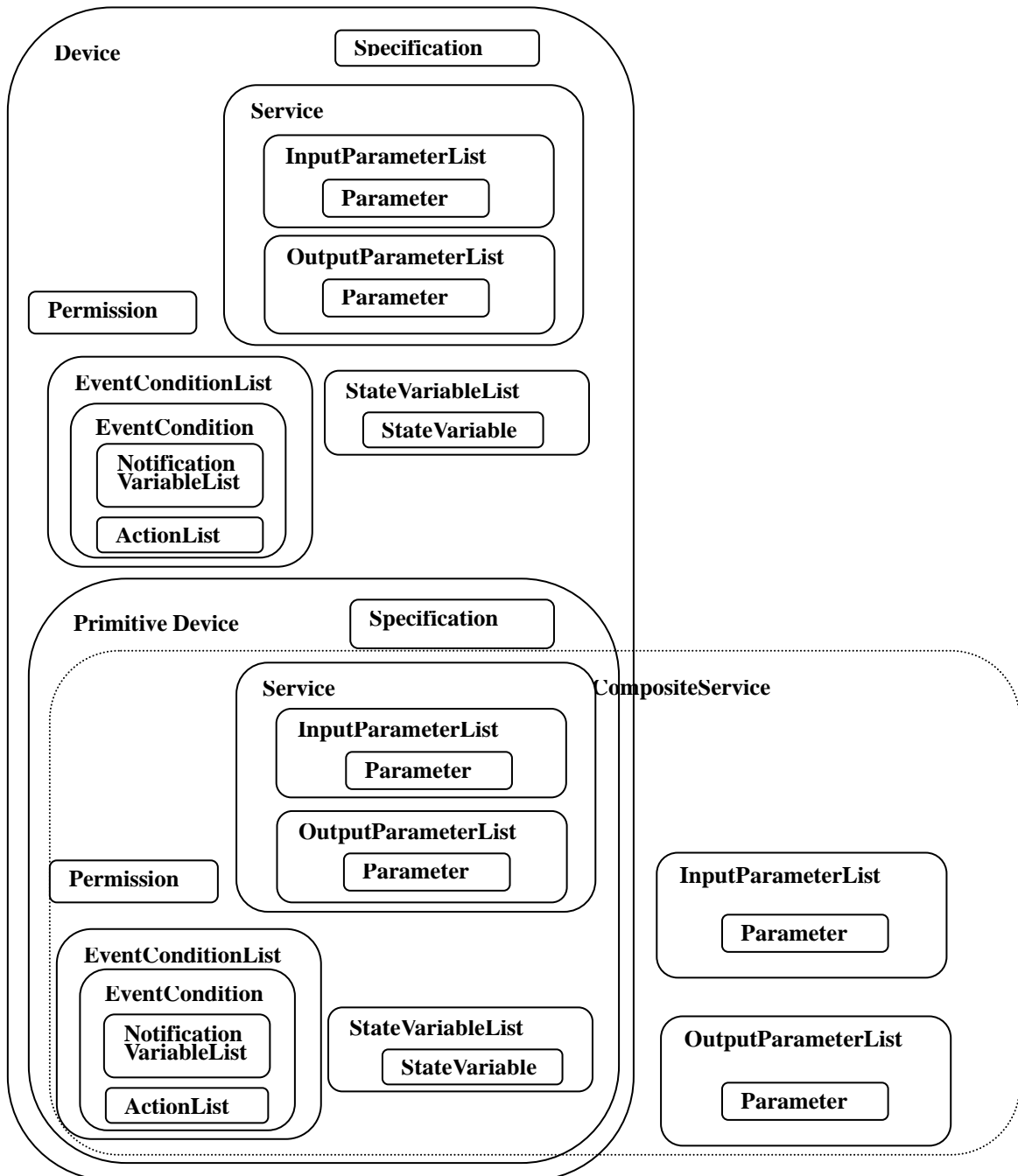

Figure 5-1: Metadata model

PUCC Device and Service Metadata Template

- ◆ ***Specification***: Description of static information of devices/primitive devices.
- ◆ ***Service***: Logical functional unit. Takes one or more input or output parameters. May have a return value.
- ◆ Parameter for service execution is described in the InputParameterList and the reply is described by the OutputParameterList
- ◆ ***Device***: Necessary devices for certain services. May embed logical devices expressed as *Primitive Devices*.
- ◆ ***Primitive Device***: Logical primitive unit for certain services.
- ◆ ***StateVariable***: A model of the state of a device or a primitive device. Has a name, data type, unit, optional default value, optional constraints values, and may be changed by services. May trigger events when its value changes.
- ◆ ***EventCondition***: Event generation condition. Event generation condition expression shall be described in the ConditionExpression element, and the state variable that is notified when the event generation condition is satisfied shall be described in NotificationVariableList. The action that is invoked when the event generation condition is satisfied shall be described in ActionList.
- ◆ ***Permission***: Specify the location for ACL(access control list). ACL defines the permission of devices and services.

5.2. Metadata Definition and XML Description

5.2.1. Device Metadata Definition

Device metadata is defined to describe devices for device discovery and to know about devices and their capabilities.

Following table shows the metadata definition for devices.

Table 5-2-1: Device metadata definition

Element name	Element Value <datatype> = XML Schema datatype	Attribute name (if present)	Attribute Value <datatype> = XML Schema datatype	Occurrence	Status
Device	XML fragment (Permission element, Specification element, StateVariableList element, ServiceList element, EventConditionList element, PrimitiveDeviceList element)	-	-	1	Required
		type	URI representing device type. <anyURI>	1	Required
		id	Global unique ID for this device. Should be < 32 characters. <string>	1	Required
		name	Short user-friendly name. Should be < 64 characters. <string>	1	Required

PUCC Device and Service Metadata Template

		private	<p>This attribute shall not be set when the device is defined by PUCC. In case the device is defined by a metadata creator, the name of the vendor etc. who performed extension shall be set.</p> <p><string></p>	1	Optional
Permission	-	-	-	1	Optional

PUCC Device and Service Metadata Template

		acl	<p>URI for ACL.</p> <p>Only this device is able to refer this URI.</p> <p>Nobody (no node or no user) is permitted to access to this device, when this value specifies empty or unexisting URI.</p> <p>Default value is an empty value("").</p> <p><anyURI></p>	1	Required
Specification	<p>XML fragment (URLBase element, Manufacturer element, ManufacturerURL element, ManufactureDate element, ModelDescription element, ModelName element, ModelNumber element, ModelURL element, SerialNumber element, UDN element, UPC element, IconList element)</p>	-	-	1	Required
URLBase	<p>Base URL. Used to construct fully-qualified URLs. All relative URLs that appear elsewhere in the metadata are combined with this base URL according to the rules in RFC2396.</p>			1	Optional

PUC C Device and Service Metadata Template

	<anyURI>				
Manufacturer	Manufacturer name. Should be < 64 characters. <string>	-	-	1	Optional
ManufacturerURL	URL to manufacture site. Specified by vendor. <anyURI>	-	-	1	Optional
ManufactureDate	Date of manufacture. <date>	-	-	1	Optional
ModelDescription	Long user-friendly name. Specified by vendor. Should be < 128 characters. <string>	-	-	1	Optional
ModelName	Model name. Specified by vendor. Should be < 32 characters. <string>	-	-	1	Optional
ModelNumber	Model number. Specified by vendor. Should be < 32 characters. <string>	-	-	1	Optional
ModelURL	URL to model site. Specified by vendor. <anyURI>	-	-	1	Optional
SerialNumber	Manufacture's serial number. Specified by vendor. Should be < 64 characters. <string>	-	-	1	Optional
UDN	Unique Device Name. Universally-unique identifier for the device. Must begin with uuid:. Specified by vendor. <anyURI>	-	-	1	Optional
UPC	Universal Product Code. Specified by vendor. 12-digit, all numeric code that identifies the consumer package. <string>	-	-	1	Optional
IconList	XML fragment (Icon element)	-	-	1	Optional

PUCC Device and Service Metadata Template

Icon	XML fragment (Mimetype element, Width element, Height element, Depth element, Url element)	-	-	1 or more	Optional
Mimetype	Icon's mime type (RFC2045, 2046, 2387). <string>	-	-	1	Required
Width	Horizontal dimension of icon in pixels. <integer>	-	-	1	Required
Height	Vertical dimension of icon in pixels. <integer>	-	-	1	Required
Depth	Number of color bits per pixel. <integer>	-	-	1	Required
Url	ID for the Icon Image <anyURI>	-	-	1	Required
StateVariableList	XML fragment (StateVariable element)	-	-	1	Required
StateVariable	XML fragment (DefaultValue element, AllowedValueList element, AllowedValueRange element)	-	-	1 or more	Optional
		name	Short user-friendly name. Should be < 32 characters. <string>	1	Required
		datatype	Variable data type. Defined in XML Schema Part2: Datatypes. <string>	1	Required
unit	Unit. <string>			1	Optional

PUCC Device and Service Metadata Template

		sendEvents	<p>“yes”/”no”.</p> <p>event messages shall be generated when the value of this state variable changes.</p> <p>Default value is “yes”.</p> <p>EventCondition List element cannot be set in case this attribute is set.</p> <p><string></p>	1	Optional
		encrypted	<p>“true”</p> <p>“false”</p> <p>Encrypted or not.</p> <p>Default value is “false”</p> <p><string></p>	1	Optional
		encryptionMethod	<p>Encryption method. In case of no encryption, this shall not be set.</p> <p><string></p>	1	Optional

PUCC Device and Service Metadata Template

		private	<p>This attribute shall not be set when the state variable is defined by PUCC. In case the state variable is defined by a metadata creator, the name of the vendor etc. who performed extension shall be set.</p> <p><string></p>	1	Optional
		accuracy	<p>The maximum deviation which is between state value and actual value.</p> <p><float></p>	1	Optional
DefaultValue	Expected, initial value. Must match data type. Must satisfy AllowedValueList or AllowedValueRange constraints.	-	-	1	Optional
AllowedValueList	XML fragment (AllowedValue element)	-	-	1	Optional
AllowedValue	A legal value for a string variable. Should be < 32 characters.	-	-	1 or more	Required

Pucc Device and Service Metadata Template

AllowedValueRange	XML fragment (Minimum element, Maximum element, Step element)	-	-	1	Optional
Minimum	Inclusive lower bound. <integer> or <float> or <double>	-	-	1	Required
Maximum	Inclusive upper bound. <integer> or <float> or <double>	-	-	1	Required
Step	Size of an increment operation. <integer> or <float> or <double>	-	-	1	Optional
ServiceList	XML fragment (Service element)	-	-	1	Required
Service	Empty if the service metadata itself is defined in the other XML document, or XML fragment(InputParameterList element, OutputParameterList element)	-	-	1 or more	Optional
		type	URI representing service type. <anyURI>	1	Required
		name	Short user-friendly name. Should be < 32 characters. <string>	1	Required

PUCC Device and Service Metadata Template

		private	This attribute shall not be set when the service is defined by PUCC. In case the service is defined by a metadata creator, the name of the vendor etc. who performed extension shall be set. <string>	1	Optional
PrimitiveDevice List	XML fragment (PrimitiveDevice element)	-	-	1	Required
PrimitiveDevice	Empty if the primitive device metadata is defined in the other XML document, or XML fragment (Permission element, Specification element, StateVariableList element, ServiceList element,EventConditionList element,,PrimitiveDeviceList element(※1))	-	-	1 or more	Optional
		type	URI representing primitive device type. <anyURI>	1	Required
		id	Global unique ID for this primitive device. Should be < 32 characters. <string>	1	Required

PUC Device and Service Metadata Template

		name	Short user-friendly name. Should be < 64 characters. <string>	1	Required
EventCondition List	XML Fragment (EventCondition element)	-	-	1	Optional
EventCondition	XML Fragment (ConditionExpression element,NotificationVariableList element,ActionList element)	-	-	1 or more	Required
		id	Event generation condition ID. The ID is unique in a device. <string>	1	Required
ConditionExpression	Event condition expression In case both condition expression and time attribute or period attribute are set, if the conditions described in the condition expression are satisfied at the specified period or time, the even shall be generated.	-	-	1	Required
		format	Type .of condition expression description format "PUC", "SQL", "SPARQL", etc. Default value is "PUC". <string>	1	Optional
		period	Even generation period. <string>	1	Optional

PUCC Device and Service Metadata Template

		time	Even generation time. <dateTime>	1	Optional
NotificationVariableList	XML Fragment (StateVariable element)	-	-	1	Optional
StateVariable	State variable for which event notification is performed. Element value shall not be set.	-	-	1 or more	Required
		name	Name of the state variable for which event notification is performed. <string>	1	Required
		notificationType	Either notify the difference of the state variable specified by the name attribute or notify the state variable value as it is. "normal" or "difference". Default value is "normal". <string>	1	Optional
ActionList	XML Fragment (Action element)	-	-	1	Optional
Action	XML Fragment (TargetNode element, TargetDevice element, TargetService element, InputParameterList element)	-	-	1 or more	Required
TargetNode	Node ID for the target node. <string>	-	-	1	Optional
TargetDevice	Device ID for the target device or the target primitive device. <string>	-	-	1	Optional

Pucc Device and Service Metadata Template

TargetService	URI for the target service. <anyURI>	-	-	1	Required
---------------	--------------------------------------	---	---	---	----------

※ Stratum of one PrimitiveDevice shall be maxim 2 strata (Device-PrimitiveDevice-PrimitiveDevice).

◆ **XML Description**

Following figure shows the template of device metadata.

```

<?xml version="1.0"?>
<Device type="URI representing device type" id="global unique ID for this device" name="short user-friendly name">
  <Permission acl="URI for ACL" />
  <Specification>
    <URLBase>base URL for all relative URLs</URLBase>
    <Manufacturer>manufacturer name</Manufacturer>
    <ManufacturerURL>URL to manufacturer site</ManufacturerURL>
    <ManufactureDate>date of manufacture</ManufactureDate>
    <ModelDescription>long user-friendly name</ModelDescription>
    <ModelName>model name</ModelName>
    <ModelNumber>model number</ModelNumber>
    <ModelURL>URL to model site</ModelURL>
    <SerialNumber>manufacturer's serial number</SerialNumber>
    <UDN>uuid:UUID</UDN>
    <UPC>Universal Product Code</UPC>
    <IconList>
      <Icon>
        <Mimetype>image/format</Mimetype>
        <Width>horizontal pixels</width>
        <Height>vertical pixels</height>
        <Depth>color depth</depth>
        <Url>ID for the Icon Image </Url>
      </icon>
      XML to declare other icons, if any, go here
    </IconList>
  </Specification>
  <StateVariableList>

```

PUCC Device and Service Metadata Template

```

<StateVariable name="short user-friendly name" datatype="variable data type" sendEvents="yes or no">
  <DefaultValue>default value</DefaultValue>
  <AllowedValueList>
    <AllowedValue>enumerated value</AllowedValue>
    Other allowed values (if any) go here
  </AllowedValueList>
</StateVariable>
<StateVariable name="short user-friendly name" datatype="variable data type" sendEvents="yes or no">
  <DefaultValue>default value</DefaultValue>
  <AllowedValueRange>
    <Minimum>minimum value</Minimum>
    <Maximum>maximum value</Maximum>
    <Step>increment value</Step>
  </AllowedValueRange>
</StateVariable>
<StateVariable name="short user-friendly name" datatype="variable data type" sendEvents="yes or no"
private="vendor name">
  <DefaultValue>default value</DefaultValue>
  <AllowedValueList>
    <AllowedValue>enumerated value</AllowedValue>
    Other allowed values (if any) go here
  </AllowedValueList>
</StateVariable>
XML to declare other state variables, if any, go here
</StateVariableList>
<ServiceList>
  <Service name="short user-friendly name" type="URI representing service type"/>
  <Service name="short user-friendly name" type="URI representing service type" private="vendor
name"/>
XML to declare other services, if any, go here
</ServiceList>
<PrimitiveDeviceList>
  <PrimitiveDevice type="URI representing device type" id="global unique ID for this primitive device"
name="short user-friendly name" >

```

PUCC Device and Service Metadata Template

<p>Description of primitive devices (if any) go here</p> <pre></PrimitiveDevice></pre> <p>Description of embedded primitive devices (if any) go here</p> <pre></PrimitiveDeviceList></pre> <pre><EventConditionList></pre> <pre><EventCondition id="Event generation condition ID"></pre> <pre><ConditionExpression>Event generation condition expression</ConditionExpression></pre> <pre><NotificationVariableList></pre> <pre><StateVariable name="Name attribute of state variable intended to be notified "/></pre> <pre><StateVariable name="Name attribute of state variable intended to be notified " notificationType="normal</pre> <p>or difference"/> <pre></NotificationVariableList></pre> <pre></EventCondition></pre> <pre><EventCondition id="Event generation condition ID"></pre> <pre><ConditionExpression format="Type of event condition expression" period="Event generation</pre> <p>period">Describe event generation condition expression</ConditionExpression> <pre><NotificationVariableList></pre> <pre><StateVariable name=" Set name attribute of state variable intended to be notified"/></pre> <pre></NotificationVariableList></pre> <pre></EventCondition></pre> <pre><EventCondition id="Event generation condition ID "></pre> <pre><ConditionExpression format="Type of event condition expression " time="Event generation</pre> <p>time">Describe event generation condition expression</ConditionExpression> <pre><NotificationVariableList></pre> <pre><StateVariable name=" Set name attribute of state variable intended to be notified"/></pre> <pre></NotificationVariableList></pre> <pre></EventCondition></pre> <pre></EventConditionList></pre> <pre><ActionList></pre> <pre><Action></pre> <pre><TargetNode>Node ID for the target node</TargetNode></pre> <pre><TargetDevice>Device ID for the target device or the target primitive device</TargetDevice></pre> <pre><TargetService>URI for the target service</TargetService></pre> <pre><InputParameterList></pre> </p></p></p>
--

PUCC Device and Service Metadata Template

```
<Parameter name="Short user-friendly name">Parameter value</Parameter>
</InputParameterList>
</Action>
</ActionList>
</Device>
```

Figure 5-2-1: Template for PUCC Device metadata

5.2.2. Service Metadata Definition

Service metadata is defined to describe services of devices for service discovery and service invocation. Following table shows the metadata definition for services.

Table5-2-2: Service metadata definition

Element name	Element Value <datatype> = XML Schema datatype	Attribute name (if present)	Attribute Value <datatype> = XML Schema datatype	Occurrence	Status
Service	XML fragment (InputParameterList element, OutputParameterList element)	-	-	1	Required
		type	URI presenting service type. <anyURI>	1	Required
		name	Short user-friendly name. Should be < 32 characters. <string>	1	Required

PUCC Device and Service Metadata Template

		private	<p>This attribute shall not be set when the service is defined by PUCC. In case the service is defined by a metadata creator, the name of the vendor etc. who performed extension shall be set.</p> <p><string></p>	1	Optional
InputParameter List	XML fragment (Parameter element)	-	-	1	Required
OutputParameterList	XML fragment(Parameter element)	-	-	1	Required
Parameter	XML fragment (DefaultValue element, AllowedValueList element, AllowedValueRange element)	-	-	1 or more	Optional
		name	<p>Short user-friendly name. Should be < 32 characters.</p> <p><string></p>	1	Required
		datatype	<p>Variable data type. Defined in XML Schema Part2:</p>	1	Optional (Required if relatedStateVariable attribute is

Pucc Device and Service Metadata Template

			Datatypes. <string>		unset.)
		relatedStateVariable	Related state valuable name. Should be < 32 characters. <string>	1	Optional (Required if datatype attribute is unset.)
		private	This attribute shall not be set when the parameter is defined by Pucc. In case the parameter is defined by a metadata creator, the name of the vendor etc. who performed extension shall be set. <string>	1	Optional
DefaultValue	Expected, initial value. Must match data type. Must satisfy AllowedValueList or AllowedValueRange constraints.	-	-	1	Optional (Not required if relatedStateVariable attribute of this parent element is set.)
AllowedValueList	XML fragment (AllowedValue element)	-	-	1	Optional (Not required if relatedStateVariable attribute of this parent

PUCC Device and Service Metadata Template

					element is set.)
AllowedValue	A legal value for a string variable. Should be < 32 characters. <string>	-	-	1 or more	Required
AllowedValueRange	XML fragment (Minimum element, Maximum element, Step element)	-	-	1	Optional (Not required if relatedStateVariable attribute of this parent element is set.)
Minimum	Inclusive lower bound. <integer> or <float> or <double>	-	-	1	Required
Maximum	Inclusive upper bound. <integer> or <float> or <double>	-	-	1	Required
Step	Size of an increment operation. <integer> or <float> or <double>	-	-	1	Optional

◆ **XML Description**

```

<?xml version="1.0"?>
<Service type="URI representing service type" name="short user-friendly title">
  <InputParameterList>
    <Parameter name="short user-friendly name" datatype="variable data type" />
    <Parameter name="short user-friendly name" relatedStateVariable="related state variable" />
    <Parameter name="short user-friendly name" relatedStateVariable="related state variable"
private="vendor name"/>
    <Parameter name="short user-friendly name" datatype="variable data type">
      <DefaultValue>default value</DefaultValue>
      <AllowedValueList>
        <AllowedValue>enumerated value</AllowedValue>
        XML to declare other allowed values, if any, go here
      </AllowedValueList>
    </Parameter>
  </InputParameterList>
</Service>

```

PUCC Device and Service Metadata Template

```

<Parameter name="short user-friendly name" datatype="variable data type">
  <DefaultValue>default value</DefaultValue>
  <AllowedValueRange>
    <Minimum>minimum value</Minimum>
    <Maximum>maximum value</Maximum>
    <Step>increment value</Step>
  </AllowedValueRange>
</Parameter>

XML to declare other input parameters, if any, go here
</InputParameterList>
<OutputParameterList>
  <Parameter name="short user-friendly name" datatype="variable data type"/>
  <Parameter name="short user-friendly name" relatedStateVariable="related state variable"/>
  <Parameter name="short user-friendly name" relatedStateVariable="related state variable"
private="vendor name"/>
  <Parameter name="short user-friendly name" datatype="variable data type">
    <DefaultValue>default value</DefaultValue>
    <AllowedValueList>
      <AllowedValue>enumerated value</AllowedValue>
      XML to declare other allowed values, if any, go here
    </AllowedValueList>
  </Parameter>
  <Parameter name="short user-friendly name" datatype="variable data type">
    <DefaultValue>default value</DefaultValue>
    <AllowedValueRange>
      <Minimum>minimum value</Minimum>
      <Maximum>maximum value</Maximum>
      <Step>increment value</Step>
    </AllowedValueRange>
  </Parameter>

XML to declare other output parameters, if any, go here
</OutputParameterList>
</Service>

```

Figure 5-2-2: Template for PUCC Service metadata

5.2.3. Composite Service Metadata Definition

Composite service is a concept of a service which is composed of several services on several devices. To metadata definition for composite services is the same with the service definition.

5.2.4. Data Type

State variables and service parameters define data formats. Data formats that can be set are as follows:

- ◆ All the data formats defined in “XML Schema Part 2: Datatypes”, W3C Recommendation 28 October 2004 3. Built-in datatypes. Name space prefix of XML Schema shall not be described.
- ◆ array : Indicates array.

In case the number of elements is specified, it shall be described after "array" by delimiting with ";".

Example.

```
datatype = "array;5"
```

In case the number of elements is not specified, nothing shall be described after "array". This shall mean variable length array. The array element shall be indicated as a sub-element of the corresponding element.

Example. Variable length array

```
<Parameter name="aaa" datatype="array">  
  <Parameter name="bbb" datatype="integer"/>  
</Parameter >
```

Example. Fixed length array

```
<Parameter name="xxx" datatype="array;3">  
  <Parameter name="yyy" datatype="string"/>  
</Parameter >
```

- ◆ struct : Indicates structure

The member of a structure shall be indicated as a sub-element of the corresponding element.

Example. Structure

```
<Parameter name="aaa" datatype="struct">  
  <Parameter name="bbb" datatype="integer"/>
```

Pucc Device and Service Metadata Template

```
<Parameter name="ccc" datatype="string"/>
<Parameter name="ddd" datatype="anyURI"/>
</Parameter >
```

In the array of a structure, a sub-element of the corresponding element shall indicate the element (structure) of array, and the member of the structure shall be set in the sub-element.

Example. Array of a structure

```
<Parameter name="aaa" datatype="array">
  <Parameter name="bbb" datatype="struct">
    <Parameter name="ccc" datatype="integer"/>
    <Parameter name="ddd" datatype="string"/>
  </Parameter >
</Parameter >
```

In case an array is possessed as a member of a structure, the array shall be set in the sub-element of the corresponding element. The array element shall be set in sub-sub- element.

Example. Array as a member of a structure

```
<Parameter name="aaa" datatype="struct">
  <Parameter name="bbb" datatype="array">
    <Parameter name="ccc" datatype="integer"/>
  </Parameter >
  <Parameter name="ddd" datatype="string"/>
</Parameter >
```

◆ xml : Indicates XML.

When XML is set, the name space of the XML document to be set shall be separated from the name space of Pucc device metadata. Name space identifier shall be set in the highest element of the XML document to be set.

Example. XML

```
<Parameter name="aaa" datatype="xml">
  <xxx xmlns="http://yyy.org/zzz">
    <yyy>zzz</yyy>
  </xxx>
</Parameter >
```

PUCC Device and Service Metadata Template

6. Event Generation Condition Expression (ConditionExpression)

6.1. Description Method of Event Generation Condition

Event generation condition shall be described as condition expression. In case the result of the condition expression is true, an event shall be generated, and in case it is false, an event shall not be generated.

6.2. Condition Expression

6.2.1. Comparison of State Variables and Certain Values

Table6.2.1-1 Comparison of state variables and certain values

	Type	Operator	Remarks
1	smaller	<	Numeric value
2	equal or smaller	<=	Numeric value
3	greater	>	Numeric value
4	equal or greater	>=	Numeric value
5	equality	==	Both numeric values and character strings
6	inequality	!=	Both numeric values and character strings

※ When described in metadata, < and > shall be described as < and > (entity reference format) respectively.

6.2.2. Reserved Word Used for Condition Expression

Table6.2.2-1 Reserved Word Used for condition expression

	Type	Remarks
1	true	Indicates a true value.
2	false	Indicates a false value.

6.2.3. Functions Described in Condition Expression

Table 6.2.3-1 Functions used for condition expression

	Return value	Function name and argument	Description
1	Value of state variable before change	previousValue (state variable name)	Acquire the value of state variable before change.
2	integer	arrayLength (state variable name)	Acquire the number of elements of array type state variable.
3	integer	previousArrayLength (state variable name)	.Acquire the number of elements of previous array type state variable.
4	boolean	contains (state variable name)	Character strings match.
5	boolean	startsWith(state variable name)	Character strings match.
6	boolean	endsWith (state variable name)	Character strings match.

6.2.4. Operator Used for Condition Expression

Table 6.2.4-1 Operator used for condition expression

	Type	Operator	Remarks
1	Arithmetic operators	+, -, *, /, %	-
2	Prioritization with parenthesis	()	-

※ When described in metadata, < and > shall be described as < and > (entity reference format) respectively.

6.2.5. Time, Period

Table 6.2.5-1 Time, period

	Type	Remarks
1	Specifies time	Shall conform to the description of date type or time type

PUCC Device and Service Metadata Template

		of W3C XML Schema Part2:Datatypes
2	Specifies period	Shall conform to the description of duration type of W3C XML Schema Part2:Datatypes

6.2.6. Multiple Usages of Condition Expression

Table 6.2.6-1 Multiple usages of condition expression

	Type	Usages	Remarks
1	AND condition	Same state variables	-
2		Different state variables	-
3		State variables and time/period	-
4	OR condition	Same state variables	-
5		Different state variables	-
6		State variables and time/period	-

6.3. Example of Description of Condition Expression

Examples of description of condition expression to be set in the ConditionExpression element of device metadata are indicated as follows:

Example 1. Event notification shall be performed when the value of the state variable Temperature is changed.

Compare the return value of previousValue function that acquires the previous state variable value and the current state variable.

```
<ConditionExpression>previousValue(Temperature)!=Temperature</ConditionExpression>
```

List 6.3-1 Example of description of condition expression ①

Example 2. Event notification shall be performed when the number of elements of the array type state variable ICTagList is changed.

Compare the return value of previousArrayLength function that acquires the number of elements of the previous array and the number of elements of the current array.

```
<ConditionExpression>previousArrayLength(ICTagList)!=arrayLength(ICTagList)</ConditionExpression>
```

List 6.3-2 Example of description of condition expression ②

Appendix A. Version History

(This appendix does not form an integral part of this specification.)

Document number	Date	Note
Pucc Device and Service Metadata Template	30 Sep, 2007	Version 1.0
Pucc Device and Service Metadata Template	31 Nov,2009	Version 2.0
Pucc Device and Service Metadata Template	30 Jun,2010	Version 2.x

Appendix B. Metadata description guideline of virtual device for collectively controlling devices

B.1. Outline

The model for PUCC device, service metadata shall consider each product as 1 device. In this model, services are executed for each product.

However, cases where services being executed collectively with multiple products are also assumed. In those cases, each product shall be described as a primitive device and a virtual product for collectively controlling them shall be described as a device.

The guideline for describing the model that uses the above mentioned virtual device in metadata is indicated as follows:

B.2. Model

The following diagrams indicate the device configurations assumed by the 2 types of models described above. Corresponding contents of metadata are also described.

(1) Models that consider each product as 1 device

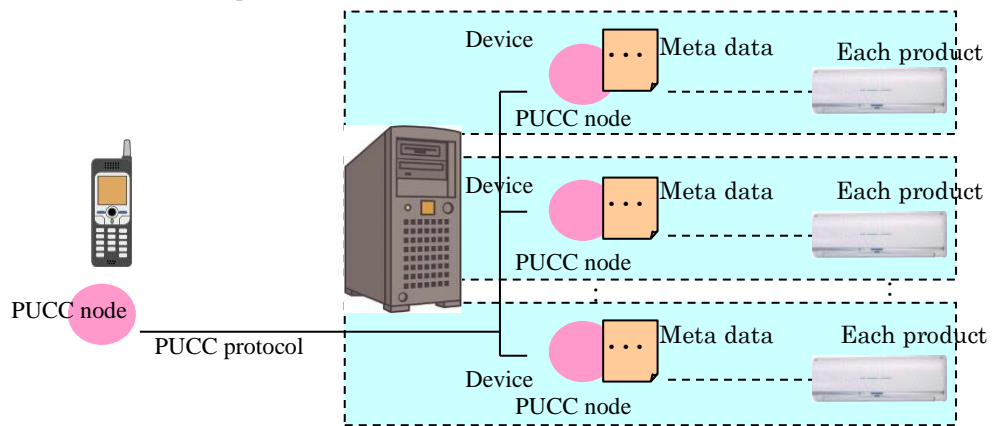
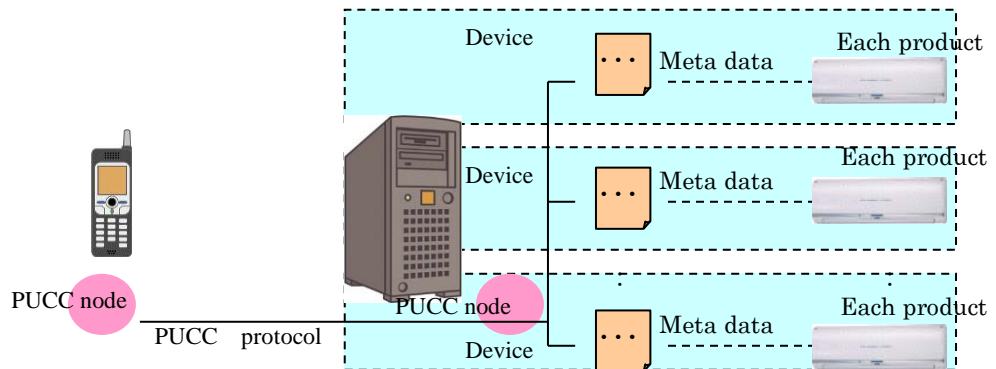

Fig. B.2-1 Model that considers each product as 1 device (1)



PUCC Device and Service Metadata Template

Fig. B.2-2 Model that considers each product as 1 device (2)

In this model, device metadata exists in each product. The following contents shall be described in the device metadata.

Table B.2-1 Contents of metadata description of the model that considers each product as 1 device

	Metadata element ('@' is an attribute)	Description
1	Device	Defines each product as a device.
2	@type	Defines device type of each product in the URI format.
3	@id	Defines device ID of each product
4	@name	Defines device name of each product.
5	Specification	Defines static data of each product.
6	ServiceList	Defines services that each product provides
7	StateVariableList	Defines state variables that each product manages.
8	EventConditionList	Defines event generation conditions that each product possesses.
9	Primitive Device	Defines logical service execution unit included in each product as PrimitiveDevice.
10	@type	Defines device type of logical service execution unit included in each product in the URI format.
11	@id	Defines ID of logical service execution unit included in each product.
12	@name	Defines a name with readability of logical service execution unit included in each product.
13	Specification	Defines static data of logical service execution unit included in each product.
14	ServiceList	Defines services that logical service execution unit included in each product provides.
15	StateVariableList	Defines state variables that logical service execution unit included in each product manages.
16	EventConditionList	Defines event generation conditions that logical service execution unit included in each product possesses.

PUCC Device and Service Metadata Template

(2) Model to define a virtual device for collectively controlling a product group

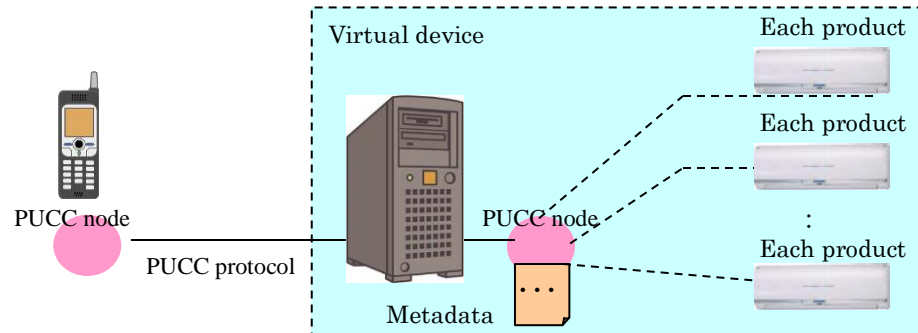

Fig. B.2-2 Model to define a virtual device for collectively controlling a product group

In this model, only the virtual device for collectively controlling a product group possesses device metadata.

The following contents are described in the device metadata. :

Table B.2-2 Contents of metadata description of a model defining a virtual device for collectively controlling a product group

	Metadata element ('@' is an attribute)	Contents of description
1	Device	Defines a virtual device for collectively controlling a product group as Device.
2	@type	Defines the device type of a virtual device for collectively controlling a product group in the URI format.
3	@id	.Defines the device ID of a virtual device for collectively controlling a product group in the URI format.
3	@name	Defines the name of a virtual device for collectively controlling a product group.
4	Specification	Defines the static data of a virtual device for collectively controlling a product group.
5	ServiceList	Defines the service of a virtual device for collectively controlling a product group.
6	StateVariableList	Defines the state variables related to the services a virtual device for collectively controlling a product group

PUCC Device and Service Metadata Template

			provides. However, duplicated management with the state variable possessed by the product group shall not be described.
7		EventConditionList	Defines the event generation condition possessed by the virtual device for collectively controlling a product group.
7	PrimitiveDevice		Defines each product as a PrimitiveDevice.
8		@type	Defines the device type of each product in the URI format.
9		@name	Defines the name with readability of each product.
10		Specification	Defines the static data of each product.
11		ServiceList	Defines the services of each product.
12		StateVariableList	Defines the state variables each product manages.
13		EventConditionList	Defines event generation condition possessed by each product.

※ Shaded area is the virtual device specific portion.

※ In case the products to be collectively controlled (primitive device) need to further define PrimitiveDevice elements inside of them, the PrimitiveDevice elements need to be described in a nested manner.

B.3. Guideline of metadata definition of virtual device

The following indicates the guideline for the contents of metadata description of virtual device.

(1) Device type

Newly defines the device type of virtual device (URI format) .

The following indicates the format of device type.

Format:

<http://www.pucc.jp/2007/09/BundledDevice/XXXXXX>

Describe “BundledDevice” character strings expressing virtual devices instead of “Device” character strings expressing devices.

XXXXXX: Describes arbitrary character strings for identifying virtual devices. It shall also be possible to insert “/” for delimitation. Shall conform to the contents of description of primitive device corresponding to collective control.

(2) Device name

Not defined.

(3) Static data

Not defined.

PUCC Device and Service Metadata Template

(4) Service

As for the services for the virtual device, services to collectively control actual product (primitive device) group and virtual device specific services shall be defined.

Virtual device specific services shall not be specified.

Services to collectively control actual product (primitive device) shall be defined as follows:

i. Service contents

Define “services commonly possessed” by the primitive device group corresponding to the collective control.

“Services commonly possessed” means the services with the same contents.

ii. Service name

Shall conform to the name of the “services commonly possessed” by the actual product (primitive device) group.

iii. Service type

Newly define values different from those provided by the service types (URI types) provided by the actual product (primitive device) group.

The following indicates the format of service type.

Format:

<http://www.pucc.jp/2007/09/BundledDevice/XXXXXX/Service/YYYYYY>

Describes “BundledDevice” character strings expressing virtual devices instead of “Device” character strings expressing devices.

XXXXXX : Describes arbitrary character strings for identifying virtual devices. It shall also be possible to insert “/” for delimitation. Shall conform to the contents of description of primitive device corresponding to collective control.

YYYYYY : Describes the character string same as the service name.

iv. Contents of service parameter

Input parameters of collective control service of virtual device shall possess the same number and data-type input parameters as the “ services commonly possessed” by the actual products (primitive devices) .

Output parameters of collective control service of virtual device shall possess the same number and data-type output parameters as the “ services commonly possessed” by the actual products (primitive devices) . However, output parameters shall be defined as arrays to enable acquisition per actual product (primitive device) .

It shall be possible to acquire output parameter values per actual product (primitive device) as array elements.

The order of the arrays shall be the description order of primitive devices inside the PrimitiveDeviceList

Pucc Device and Service Metadata Template

elements of metadata.

Output parameters of success/failure of collective control services shall not be described. Handling of the output parameters per actual product (primitive device) shall depend on the application on the service execution side.

v. Name of service parameters

Shall conform to the input/output parameter names of the “commonly possessed services” by the actual product (primitive device) group.

As for the arrays of the output parameters, “bundled” shall be added as the prefix in the beginning of the “commonly possessed services “ by the actual product (primitive device) group .

vi. State variables that service parameters refer to

Shall describe the name (name attribute) of the “commonly possessed state variables “ by the actual product (primitive device) group . “Commonly possessed state variables “ means the state variables with identical contents of state variables, names and data format.

Example of description of service metadata”

```
<Service name="GetOperationStatus"
  type="http://www.pucc.jp/2007/09/BundledDevice/Echonet/Light/Service/GetOperationStatus">
  <InputParameterList/>
  <OutputParameterList>
    <Parameter name="bundledCurrentOperationStatus" datatype="array">
      <Parameter name="CurrentOperationStatus" relatedStateVariable="OperationStatus"/>
    </Parameter>
  </OutputParameterList>
</Service>
```

Table B.3-1. Description of example of service metadata description

	Item	Description
1	Contents of service	Shall define the GetOperationStatus service commonly possessed by the actual products (PrimitiveDevice) .
2	Service name	Shall define the same name as that of GetOperationStatus service commonly possessed by the actual product (PrimitiveDevice) .
3	Service type	The Device commonly possessed by the actual product (PrimitiveDevice) http://www.pucc.jp/2007/09/Device/Echonet/Light/Service/GetOperationStatus shall be changed to BundledDevice and defined as http://www.pucc.jp/2007/09/BundledDevice/Echonet/Light/Service/GetOperationStatus
4	Contents of	Shall define the same contents as the input parameters (none) of the

PUCC Device and Service Metadata Template

	service parameter	GetOperationStatus services commonly possessed by the actual products (PrimitiveDevice) and the output parameters (CurrentOperationStatus) . Note that output parameters shall be defined as arrays.
5	Service parameter name	Shall define with the same name as the input parameters (none) of the GetOperationStatus services commonly possessed by the actual products (PrimitiveDevice) and the output parameters (CurrentOperationStatus) .Note that the name of arrays of output parameters shall be CurrentOperationStatus by adding bundled as a prefix.
6	State variables referred to by service parameter	State variable name called OperationStatus possessed commonly by the actual products (PrimitiveDevice) shall be set in the relatedStateVariable attribute of the parameter.

(5) State variables

Virtual device specific state variables shall be defined.

State variables referred to by the services for collectively control the actual product (primitive device) group shall not be defined in the virtual device. Avoid duplicated management with the actual device (primitive device) .

(6) Event notification of state variables

The following event notification shall be performed when the event registration is done in the virtual device.

① In case sendEvents attribute of StateVariable element is used for setting the existence of event notification

The event observation for an actual product (primitive device) is also done, when the event registration is done in the virtual device.

In case the state variables defined in the virtual device is changed, or the values of state variables of the actual product (primitive device) referred to by the collective control service is changed, event notification shall be performed.

In that case, the state variables and values to be event notified shall be defined as arrays, as is the case for the output parameters of the collective control services, so that acquisition can be performed per actual product (primitive device) .

It shall be possible to acquire output parameter values per actual product (primitive device) as array elements.

PUCC Device and Service Metadata Template

The order of the arrays shall be the description order of primitive devices inside the PrimitiveDeviceList elements of metadata.

②In case event generation condition is described in the EventConditionList element

In case event monitoring is performed for the state variables defined specifically for the virtual device, event generation conditions shall be set in the EventConditionList element of the virtual device.

In case event monitoring is performed for the state variables of actual products (primitive devices) referred to by the collective control service, event generation condition shall be set in the EventConditionList element of the actual product (primitive device) .

The event registration which specified event generation conditions is done for each virtual device and actual products (primitive device), when the EventConditionList element is used.

(6) Others

Implementation method as to how virtual device executes the collective control services shall not be specified.

B.4. Example of description of metadata of the virtual device

The following indicates the examples of metadata of the virtual device.

Example. Virtual device to collectively control the power source for the lighting (xxx company's product) of ZZZ condominium.

(In the case where sendEvents attribute of StateVariable element is used for setting the existence of event notification)

```
<?xml version="1.0"?>
<Device type="http://www.pucc.jp/2007/09/BundledDevice/Echonet/Light"
      id="BundledLight" name="BundledLight">
  <Specification>
    <ModelDescription>Bundled light for ZZZ condominium building</ModelDescription>
    <IconList>
      <Icon>
        <Mimetype>image/png</Mimetype>
        <Width>48</width>
        <Height>48</height>
        <Depth>24</depth>
        <Url>http://xxx.co.jp/images/LightIcon.png</Url>
      </icon>
    </IconList>
  </Specification>
  <StateVariableList/>
  <ServiceList>
    <Service name="GetOperationStatus"
      type="http://www.pucc.jp/2007/09/BundledDevice/Echonet
```

State variables needed for collective control shall not be described (For avoiding duplicated management)

Output parameters shall be described as arrays.

PUCC Device and Service Metadata Template

```

    /Light/Service/GetOperationStatus">
    <InputParameterList>
    <OutputParameterList>
      <Parameter name="bundledCurrentOperationStatus" datatype="array">
        <Parameter name="CurrentOperationStatus"
          relatedStateVariable="OperationStatus"/>
      </Parameter>
    </OutputParameterList>
  </Service>
<Service name="SetOperationStatus"
  type="http://www.pucc.jp/2007/09/
    BundledDevice/Echonet/Light/Service/SetOperationStatus">
  <InputParameterList>
    <Parameter name="NewOperationStatus" relatedStateVariable="OperationStatus"/>
  </InputParameterList>
  <OutputParameterList>
</Service>
:
(Describe definition of other collective control service metadata)
:
</ServiceList>
<PrimitiveDeviceList>
  <PrimitiveDevice type="http://www.pucc.jp/2007/09/Device/Echonet/Light"
    id="Light1" name="Light at Living Room">
    <Specification>
      <URLBase>http://www.xxx.co.jp</URLBase>
      <Manufacturer>xxx corporation</Manufacturer>
      <ManufacturerURL>/index.html</ManufacturerURL>
      <ModelDescription>Light at Living Room</ModelDescription>
      <ModelName>AABBCC</ModelName>
      <ModelNumber>12345</ModelNumber>
      <ModelURL>/AABBCC.html</ModelURL>
      <IconList>
        <Icon>
          <MimeType>image/png</MimeType>
          <Width>48</width>
          <Height>48</height>
          <Depth>24</depth>
          <Url>/images/LightIcon.png</Url>
        </icon>
      </IconList>
    </Specification>
    <StateVariableList>
      <StateVariable name="OperationStatus" datatype="string" sendEvents="yes">
        <AllowedValueList>
          <AllowedValue>ON</AllowedValue>
          <AllowedValue>OFF</AllowedValue>

```

Shall describe state variable name of PrimitiveDevice to be referred to.

Shall describe state variable name of PrimitiveDevice to be referred

Describe metadata of actual product as PrimitiveDevice.

Definition of state variables referred to by the services of virtual device

PUCC Device and Service Metadata Template

```

    </AllowedValueList>
  </StateVariable>
  :
  (Describe definition of other state variables)
  :
</StateVariableList>
<ServiceList>
  <Service name="GetOperationStatus"
    type="http://www.pucc.jp/2007/09/
      Device/Echonet/Light/Service/GetOperationStatus">
    <InputParameterList/>
    <OutputParameterList>
      <Parameter name="CurrentOperationStatus"
        relatedStateVariable="OperationStatus"/>
    </OutputParameterList>
  </Service>
  <Service name="SetOperationStatus"
    type="http://www.pucc.jp/2007/09/
      Device/Echonet/Light/Service/SetOperationStatus">
    <InputParameterList>
      <Parameter name="NewOperationStatus"
        relatedStateVariable="OperationStatus"/>
    </InputParameterList>
    <OutputParameterList/>
  </Service>
  :
  (Describe definition of other service metadata)
  :
</ServiceList>
</PrimitiveDevice>
<PrimitiveDevice type="http://www.pucc.jp/2007/09/Device/Echonet/Light"
  id="Light2" name="Light at Dining Room">
  <Specification>
    <URLBase>http://www.xxx.co.jp</URLBase>
    <Manufacturer>xxx corporation</Manufacturer>
    <ManufacturerURL>/index.html</ManufacturerURL>
    <ModelDescription>Light at Dining Room</ModelDescription>
    <ModelName>DDEEFF</ModelName>
    <ModelNumber>67890</ModelNumber>
    <ModelURL>/DDEEFF.html</ModelURL>
    <IconList>
      <Icon>
        <Mimetype>image/png</Mimetype>
        <Width>48</width>
        <Height>48</height>
        <Depth>24</depth>
        <Url>/images/LightIcon.png</Url>
      </Icon>
    </IconList>
  </Specification>
</PrimitiveDevice>

```

Shall describe state variable name of PrimitiveDevice to be referred to.

Shall describe state variable name of PrimitiveDevice to be referred

Describe metadata of actual product as PrimitiveDevice.

Definition of state variables referred to by the services of virtual

PUCC Device and Service Metadata Template

```

</icon>
</IconList>
</Specification>
<StateVariableList>
  <StateVariable name="OperationStatus" datatype="string" sendEvents="yes">
    <AllowedValueList>
      <AllowedValue>ON</AllowedValue>
      <AllowedValue>OFF</AllowedValue>
    </AllowedValueList>
  </StateVariable>
  :
  (Describe definition of other state variables)
  :
</StateVariableList>
<ServiceList>
  <Service name="GetOperationStatus"
    type="http://www.pucc.jp/2007/09/
      Device/Echonet/Light/Service/GetOperationStatus">
    <InputParameterList/>
    <OutputParameterList>
      <Parameter name="CurrentOperationStatus"
        relatedStateVariable="OperationStatus"/>
    </OutputParameterList>
  </Service>
  <Service name="SetOperationStatus"
    type="http://www.pucc.jp/2007/09/
      Device/Echonet/Light/Service/SetOperationStatus">
    <InputParameterList>
      <Parameter name="NewOperationStatus"
        relatedStateVariable="OperationStatus"/>
    </InputParameterList>
    <OutputParameterList/>
  </Service>
  :
  (Describe definition of other service metadata)
  :
</ServiceList>
</PrimitiveDevice>
:
(Describe definition of other actual product (primitive device) )
:
</PrimitiveDeviceList>
</Device>

```

Shall describe state variable name of PrimitiveDevice to be referred

Shall describe state variable name of PrimitiveDevice to be referred

Example. Virtual device to collectively control the power source for the lighting (xxx company's product) of

PUCC Device and Service Metadata Template

ZZZ condominium

(In case Event generation condition is described in the EventConditionList element)

```

<?xml version="1.0"?>
<Device type="http://www.pucc.jp/2007/09/BundledDevice/Echonet/Light"
      id="BundledLight" name="BundledLight">
  <Specification>
    <ModelDescription>Bundled light for ZZZ condominium building</ModelDescription>
    <IconList>
      <Icon>
        <Mimetype>image/png</Mimetype>
        <Width>48</width>
        <Height>48</height>
        <Depth>24</depth>
        <Url>http://xxx.co.jp/images/LightIcon.png</Url>
      </icon>
    </IconList>
  </Specification>
  <StateVariableList/>
  <ServiceList>
    <Service name="GetOperationStatus"
      type="http://www.pucc.jp/2007/09/BundledDevice/Echonet
        /Light/Service/GetOperationStatus">
      <InputParameterList/>
      <OutputParameterList>
        <Parameter name="bundledCurrentOperationStatus" datatype="array">
          <Parameter name="CurrentOperationStatus"
            relatedStateVariable="OperationStatus"/>
        </Parameter>
      </OutputParameterList>
    </Service>
    <Service name="SetOperationStatus"
      type="http://www.pucc.jp/2007/09/
        BundledDevice/Echonet/Light/Service/SetOperationStatus">
      <InputParameterList>
        <Parameter name="NewOperationStatus" relatedStateVariable="OperationStatus"/>
      </InputParameterList>
      <OutputParameterList/>
    </Service>
    :
    (Describe the definition of other collective control service metadata)
    :
  </ServiceList>
  <PrimitiveDeviceList>
    <PrimitiveDevice type="http://www.pucc.jp/2007/09/Device/Echonet/Light"
      id="Light1" name="Light at Living Room">
      <Specification>

```

State variables needed for collective control shall not be described (For avoiding duplicated management)

Output parameters shall be described as an array.

Shall describe state variable name of PrimitiveDevice to be referred

Shall describe state variable name of PrimitiveDevice to be referred

Describe metadata of actual product as PrimitiveDevice.

PUCC Device and Service Metadata Template

```

<URLBase>http://www.xxx.co.jp</URLBase>
<Manufacturer>xxx corporation</Manufacturer>
<ManufacturerURL>/index.html</ManufacturerURL>
<ModelDescription>Light at Living Room</ModelDescription>
<ModelName>AABBCC</ModelName>
<ModelNumber>12345</ModelNumber>
<ModelURL>/AABBCC.html</ModelURL>
<IconList>
  <Icon>
    <MimeType>image/png</MimeType>
    <Width>48</width>
    <Height>48</height>
    <Depth>24</depth>
    <Url>/images/LightIcon.png</Url>
  </Icon>
</IconList>
</Specification>
<StateVariableList>
  <StateVariable name="OperationStatus" datatype="string">
    <AllowedValueList>
      <AllowedValue>ON</AllowedValue>
      <AllowedValue>OFF</AllowedValue>
    </AllowedValueList>
  </StateVariable>
  :
  (Describe definition of other state variables)
  :
</StateVariableList>
<ServiceList>
  <Service name="GetOperationStatus"
    type="http://www.pucc.jp/2007/09/
      Device/Echonet/Light/Service/GetOperationStatus">
    <InputParameterList/>
    <OutputParameterList>
      <Parameter name="CurrentOperationStatus"
        relatedStateVariable="OperationStatus"/>
    </OutputParameterList>
  </Service>
  <Service name="SetOperationStatus"
    type="http://www.pucc.jp/2007/09/
      Device/Echonet/Light/Service/SetOperationStatus">
    <InputParameterList>
      <Parameter name="NewOperationStatus"
        relatedStateVariable="OperationStatus"/>
    </InputParameterList>
    <OutputParameterList/>
  </Service>

```

Definition of state variables referred to by the services of virtual device

Shall describe state variable name of PrimitiveDevice to be referred

Shall describe state variable name of PrimitiveDevice to be referred

PUCC Device and Service Metadata Template

```

:
  (Describe definition of other service metadata)
:
</ServiceList>
<EventConditionList>
  <EventCondition id="event1">
    <ConditionExpression>previousValue(OperationStatus)!= OperationStatus
  </ConditionExpression>
  <NotificationVariableList>
    <StateVariable name="OperationStatus"/>
  </NotificationVariableList>
  </EventCondition>
</EventConditionList>
</PrimitiveDevice>
<PrimitiveDevice type="http://www.pucc.jp/2007/09/Device/Echonet/Light"
  id="Light2" name="Light at Dining Room">
  <Specification>
    <URLBase>http://www.xxx.co.jp</URLBase>
    <Manufacturer>xxx corporation</Manufacturer>
    <ManufacturerURL>/index.html</ManufacturerURL>
    <ModelDescription>Light at Dining Room</ModelDescription>
    <ModelName>DDEEFF</ModelName>
    <ModelNumber>67890</ModelNumber>
    <ModelURL>/DDEEFF.html</ModelURL>
    <IconList>
      <Icon>
        <MimeType>image/png</MimeType>
        <Width>48</width>
        <Height>48</height>
        <Depth>24</depth>
        <Url>/images/LightIcon.png</Url>
      </icon>
    </IconList>
  </Specification>
  <StateVariableList>
    <StateVariable name="OperationStatus" datatype="string" >
      <AllowedValueList>
        <AllowedValue>ON</AllowedValue>
        <AllowedValue>OFF</AllowedValue>
      </AllowedValueList>
    </StateVariable>
    :
    (Describe definition of other state variables)
    :
  </StateVariableList>
</ServiceList>
<Service name="GetOperationStatus"

```

Shall describe Event generation condition of PrimitiveDevice to be

Describe metadata of actual product as PrimitiveDevice.

Definition of state variables referred to by the services of virtual

PUCC Device and Service Metadata Template

```

type="http://www.pucc.jp/2007/09/
    Device/Echonet/Light/Service/GetOperationStatus"/>
<InputParameterList/>
<OutputParameterList>
  <Parameter name="CurrentOperationStatus"
                relatedStateVariable="OperationStatus"/>
  </OutputParameterList>
</Service>
<Service name="SetOperationStatus"
type="http://www.pucc.jp/2007/09/
    Device/Echonet/Light/Service/SetOperationStatus"/>
<InputParameterList>
  <Parameter name="NewOperationStatus"
                relatedStateVariable="OperationStatus"/>
  </InputParameterList>
<OutputParameterList/>
</Service>
:
(Describe definition of other service metadata)
:
</ServiceList>
<EventConditionList>
  <EventCondition id="event1">
    <ConditionExpression>previousValue(OperationStatus)!= OperationStatus
  </ConditionExpression>
  <NotificationVariableList>
    <StateVariable name="OperationStatus"/>
  </NotificationVariableList>
  </EventCondition>
</EventConditionList>
</PrimitiveDevice>
:
(Describe definition of other actual product (primitive device) )
:
</PrimitiveDeviceList>
</Device>

```

Shall describe state variable name of PrimitiveDevice to be referred

Shall describe state variable name of PrimitiveDevice to be referred

Shall describe Event generation condition of PrimitiveDevice to be referred to.

Appendix C. Description guideline of state variable units

State variable units can be set in the unit attribute of StateVariable element of metadata.

It is recommended that units used shall comply with the international unit system (SI), however, the international unit system has units such as "°C", "m²", etc. that cannot be described in the XML document, also, it is not possible to express all the units to be potentially used only with those defined in the international unit system. Therefore, those who define metadata shall freely decide them.

The following indicates the examples of descriptions of state variables units.

Example. Unit of Weight shall be "kg" (kilogram), unit of Height shall be "m" (meter) .

```
<Device type="Device type" id="Device ID" name="Device name">
  . . . Omit . . .
  <StateVariableList>
    <StateVariable name="Weight" datatype="integer" unit="kg"/>
    <StateVariable name="Height" datatype="integer" unit="m"/>
    :
  </StateVariableList>
  . . . Omit . . .
```

		Page52 (75)
PUCC Device and Service Metadata Template		

Appendix D. Description guideline of ACL(Access Control List)

D.1. Baseline

Access Control Method is specified in PUCC Device Meta Data. Baseline of Access Control Method for PUCC Device is shown as follows,

- Why Access Control for device is required?
 - It is required to differentiate devices NOT open for everybody from the open devices.
- It is required to establish the total system reliability by the access origin authentication when the access control is used.
 - Access control turns into meaningless when access origin information can be cheated.
 - PUCC session initiation with a mutual authentication, message encryption and a digital signature are required for establishing reliability.
- Access control is processed using the access control list stored in the device.
 - The Access Control List SHOULD be pre-installed to the target device.
 - The open devices for anybody would not have the Access Control List.
- The access origin information is described as the White List form in the Access Control List.
 - Node ID and User ID SHOULD be added to the Access Control List to permit accessing to the target device.
 - Access from the origin that is not listed in the Access Control List SHOULD be denied.

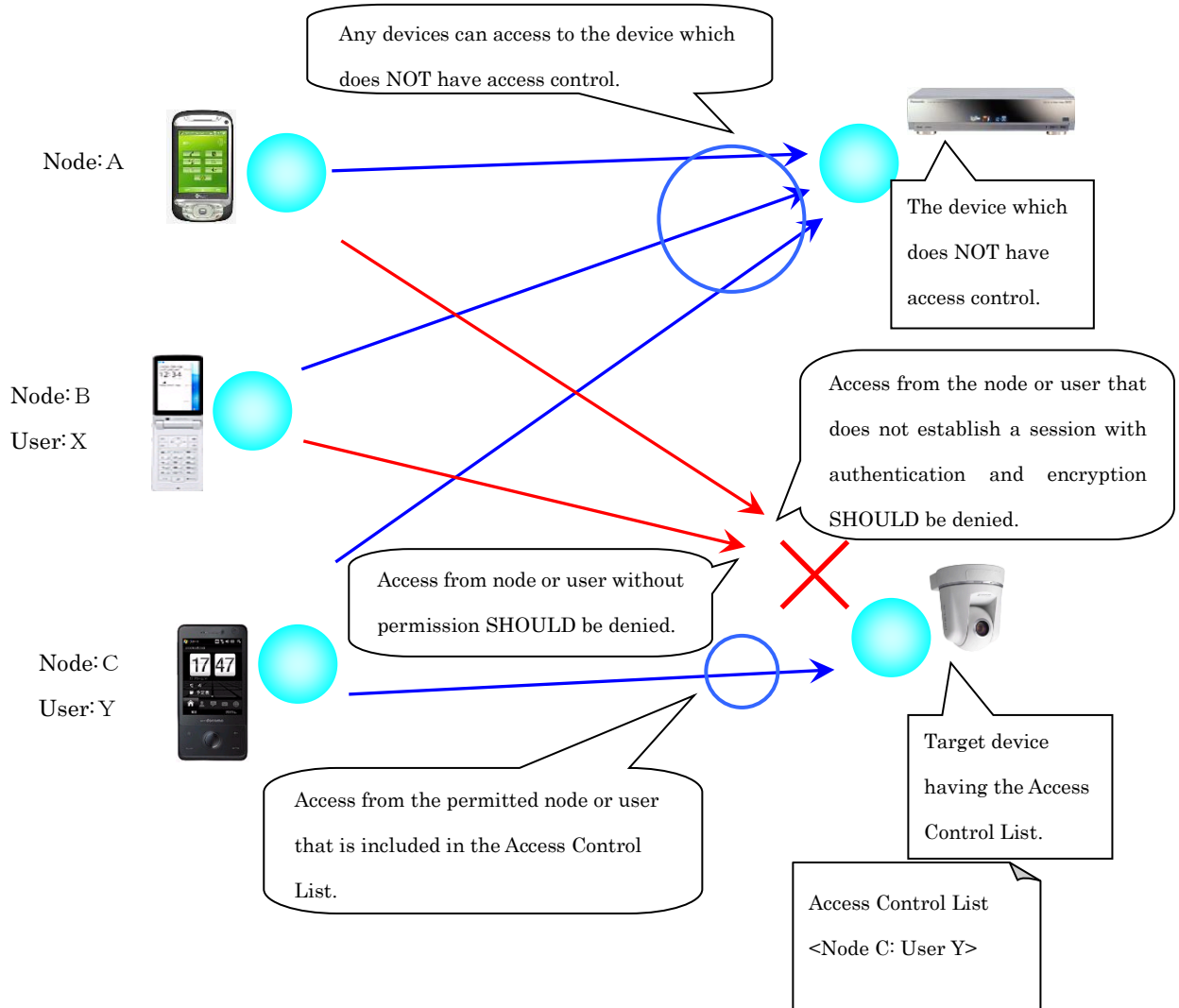

Fig. D.1-1 Device Access Control Overview

PUCC Device and Service Metadata Template

D.2. Access Control Target and Permission

Access Control target and Permission are described in the following table.

Fig. D.2-1 Access Control Target and Permission

	Target	Permission	Value	Semantics
1	Device	Discover	Allow	Respond the Device Discover Request (Discover Method) and return Metadata. Static part of Metadata SHOULD be returned.
2			Deny	NOT respond the Device Discover Request (Discover Method). Static part of Metadata SHOULD NOT be returned.
3		Service Invocation	Allow	Permit Service Invocation (Invoke Method)
4			Deny	NOT permit Service Invocation (Invoke Method)
5		Subscribe	Allow	Permit Event Subscription (Subscribe Method)
6			Deny	NOT permit Event Subscription (Subscribe Method)
7		Metadata Update (*)	Allow	Permit Device Metadata Update (Update Method)
8			Deny	Not permit Device Metadata Update (Update Method)
9	Service	Execution	Allow	Permit Service Execution specified in Metadata.
10			Deny	Not permit Service Execution specified in Metadata.
11	Event	Subscription	Allow	Permit Event subscription specified in Metadata.
12			Deny	Not permit Event subscription specified in Metadata.

*Update Method is limited to Event Condition List in Metadata.

 <p>pucc P2P Universal Computing Consortium</p>		Page55 (75)
<i>Pucc Device and Service Metadata Template</i>		

D.3. Specifying Access Control

<Permission> element is required to be placed inside of <Device> element or <PrimitiveDevice> element to show the Access Control List location.

The description of Access Control List SHOULD not be included in Metadata. The reason is that Access Control List should not be exposed to the User/Node which obtain the Metadata.

The location of Access Control List is specified as URL form by the value of “acl” attribute. The device specified <Device> element is permitted to refer the Access Control List represented by URL.

The location of Access Control List SHOULD be specified inside both or either of <Device> element or <PrimitiveDevice> element.

- When location of Access Control List is specified inside of <Device> element and not specified inside of <PrimitiveDevice>, access control to PrimitiveDevice SHOULD be inherited from the access control to Device.
- When location of Access Control List is specified inside of <PrimitiveDevice> element and not specified inside of <Device>, there SHOULD be no access control to Device (Any access SHOULD be accepted.)
- When location of Access Control List is specified inside of <Device> element and <PrimitiveDevice> respectively, access control to Device should depend on the Access Control List specified inside of <Device> element and access control to PrimitiveDevice should be depend on the Access Control List specified inside of <PrimitiveDevice>.

PUCC Device and Service Metadata Template

Example: Any access is accepted from any user/nodes.

```
<?xml version="1.0"?>
<Device type="http://www.pucc.jp/2009/03/Device/Camera" id=""
name="Camera_in_Living_room">
  <Specification>
    :
    (No <Permission> element)
```

- There is no access control specification, therefore, any access from any
- user/node is accepted.

Example: Any access from any user/node is denied.

```
<?xml version="1.0"?>
<Device type="http://www.pucc.jp/2009/03/Device/Camera" id="" name="
Camera_in_Living_room">
  <Permission acl="" />
  <Specification>
    :
```

- When Blanc value (Default value) is used for access control, any access
- from any user/node is denied.

Example: Access control by the specified Access Control List

```
<?xml version="1.0"?>
<Device type="http://www.pucc.jp/2009/03/Device/Camera" id="" name="
"Camera_in_Okamoto's_Livingroom ">
  <Permission acl="acl.txt" />
  <Specification>
    :
```

- Access is controlled by the policy specified in the Access Control List "acl.txt"
- The Access Control List SHOULD NOT be able to be referred from
- outside of the Device.

D.4. Access Control List

- Access Control List is a text file composed by the property:value pairs.
- The property and Value are separated by “:”. The property represents the access type, and accepted origin user/node is specified in the form of “UserID@NodeID” as Value.
- When any access from any node or user is accepted, NodeID or UserID SHOULD be specified using asterisk “*” respectively.
 - ✧ When NodeID is given and UserID is specified by asterisk “*”, Any access from the specified Node SHOULD be accepted with all userID.
 - ✧ When UserID is given and NodeID is specified by asterisk “*”, Any access from the specified User SHOULD be accepted with all NodeID.
 - ✧ When both UserID and NodeID are specified by asterisk “*”, Any access from any user and nodeID SHOULD be accepted.
- When any node/user can access to the Device, specifying asterisk “*” for both NodeID and UserID as Value of property or omit specifying Value. For representing clear intention, using asterisk “*” is recommended than omitting.
- When nothing is specified to Value, any access from any node/user SHOULD be denied.

The access type specified to properties are shown in Table D.4-1.

Table D.4-1 Access type

NO	Access Type	Permission
1	discover	Permission for discovering Device/Primitive Device
2	invoke	Permission for service invocation
3	invoke#Service_Name	Permission for invoking specified Service
4	subscribe	Permission for Event Subscription/Unsubscription
5	subscribe#Event_ID	Permission for Event Subscription/Unsubscription specified by Event_ID.
6	update	Permission for Meta Data update

Note : Specified permission of No2 has priority over Permission No3.

Note : Specified permission of No4 has priority over Permission No5.

PUCC Device and Service Metadata Template

Example 1.

```
invoke: userA@nodeA, *@nodeB, userC@*
subscribe: userA@nodeA
update:
```

or

```
discover: *@*
invoke: userA@nodeA, *@nodeB, userC@*
subscribe: userA@nodeA
update:
```

- All nodes/users is permitted to discover Device.
- userA using nodeA and all users using nodeB, and any nodes used by userC are permitted to invoke services.
- userA using nodeA is permitted to subscribe.
- No user/node is permitted to update metadata.

Example. 2

```
invoke#SetPower: *@nodeA
invoke#SetTime:
```

or

```
invoke#SetPower: *@nodeA
invoke#SetTime:
invoke: *@*
```

- Invoking SetPower Service is permitted to any users using nodeA.
- SetTime Service is NOT permitted to any user/node.
- Any Service other than SetPower or SetTime Service is permitted to all user/node.

Example. 3

```
invoke#SetPower: *@nodeA
invoke#SetTime:
invoke: *@nodeA, *@nodeB
```

- SetPower service is permitted to any user using nodeA.
- SetTime service is not permitted to any user/device.
- Any Service other than SetPower or SetTime Service is permitted to any user using nodeA or nodeB.

PUCC Device and Service Metadata Template

Example. 4

```
subscribe#1: userA@nodeA, *@nodeC  
subscribe#2:
```

or

```
subscribe#1: userA@nodeA, *@nodeC  
subscribe#2:  
subscribe: *@*
```

- Subscription of the event whose Event_ID is “1” is permitted to userA using nodeA or any user using nodeC.
- Subscription of the event whose Event_ID is “2” is NOT permitted to any user/node.
- Subscription of the event whose Event_ID is “2” is NOT permitted to any user/node.

Appendix E. Description guideline of Actions

Services on Device would be invoked from outside of the device. Therefore, some services could be invoked autonomously with specified device events. This autonomous service invocation is called “Action” in this document.

There are two “Action” use cases; the first usecase is the service invocation within the same device to the device having “Action”. The other usecase is the service invocation at the different device from the device having the “Action”. Each usecase is called “Local Action” and “Remote Action”.

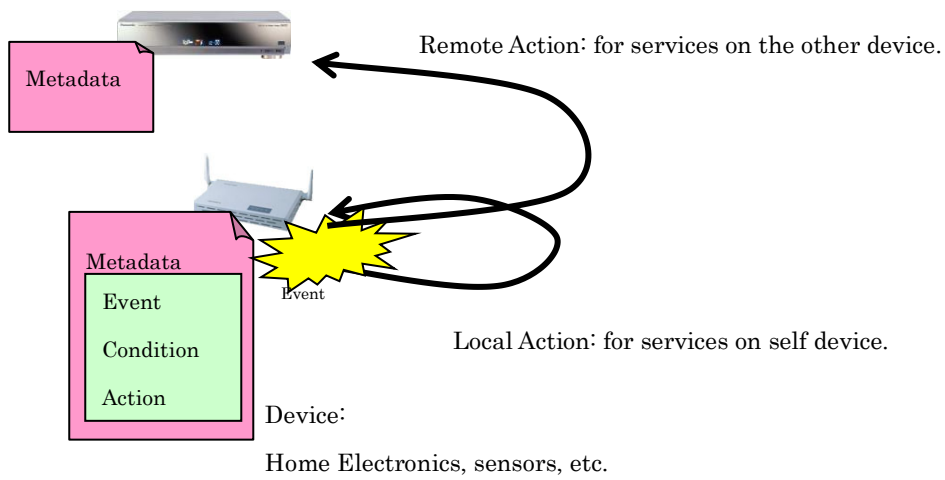

• the definition of event condition and Action SHOULD be

Figure E-1 Devices and Action

“Local Action” defines the behavior of service invocation specified in the <Device> element of metadata, when the Event Condition is satisfied at the corresponding device to <Device > element.

The Service and service parameters SHOULD be described for specifying Action.

Example. 1 When the measuring room temperature is beyond 20 degree, the air conditioner SHOULD be turned off.

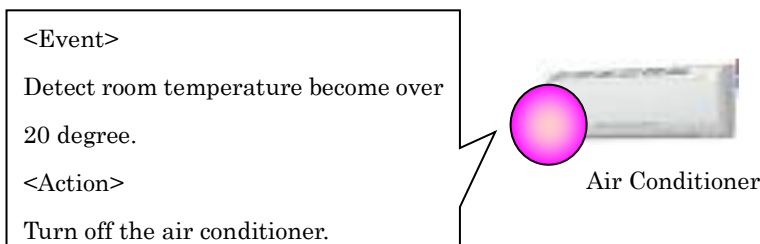
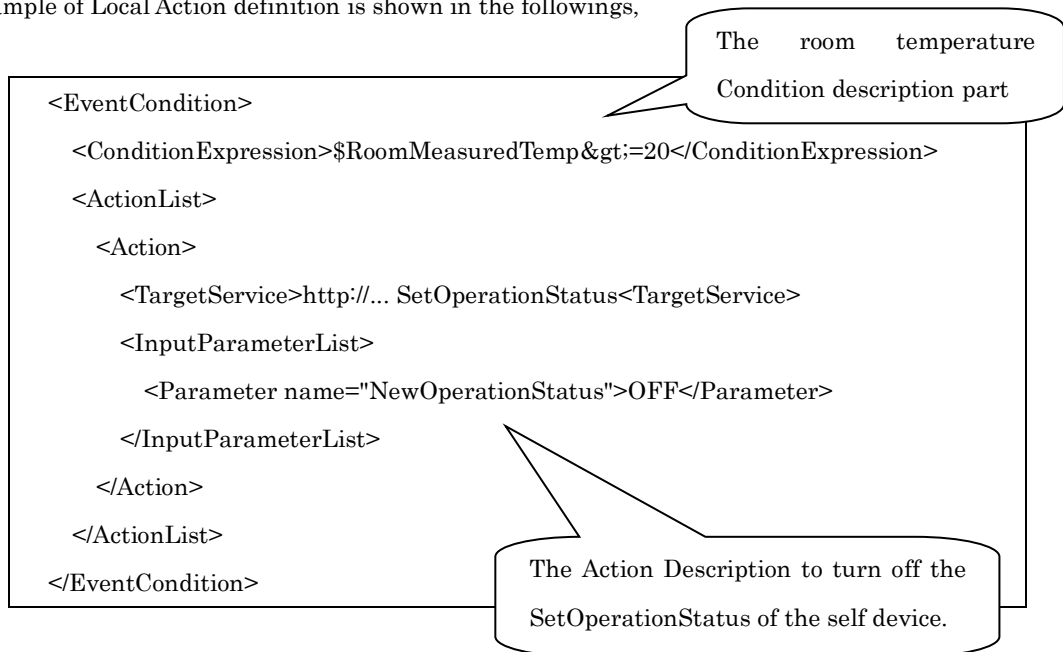

Figure E-2 LocalAction of the Air conditioner

The example of Local Action definition is shown in the followings,



PUCC Device and Service Metadata Template

Example. 2 When the measuring room temperature becomes more than 24°C, the air-conditioner's target temperature is set to be "-2°C".

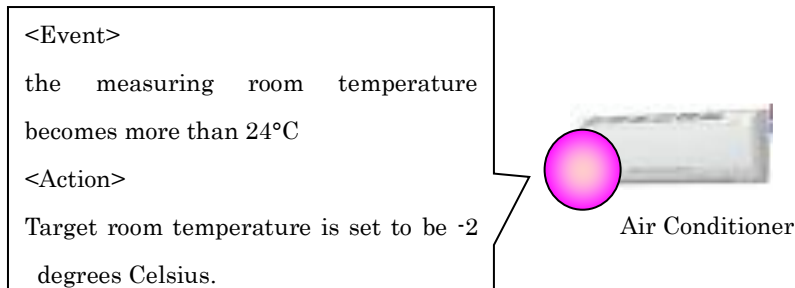
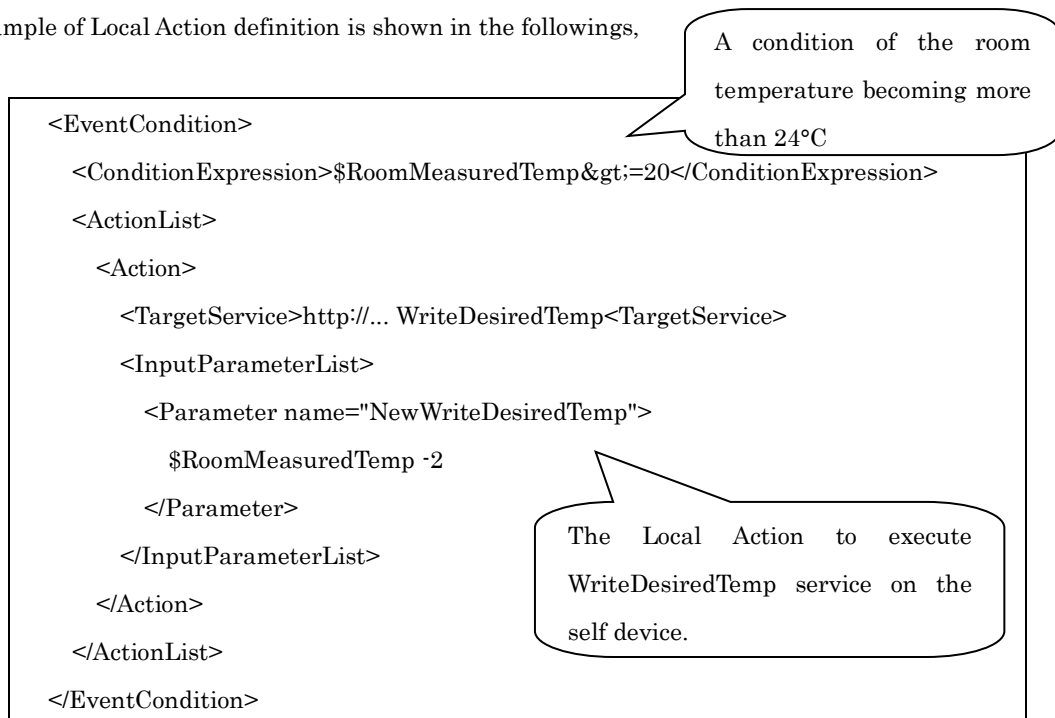

Figure. E-3 Local Action for air-conditioner

The example of Local Action definition is shown in the followings,



PUCC Device and Service Metadata Template

Example. 3 When the measuring room temperature rises more than 5°C, the air-conditioner's target temperature is set to be "-2°C".

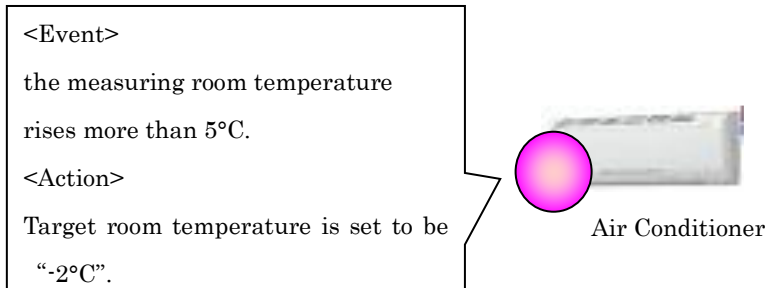
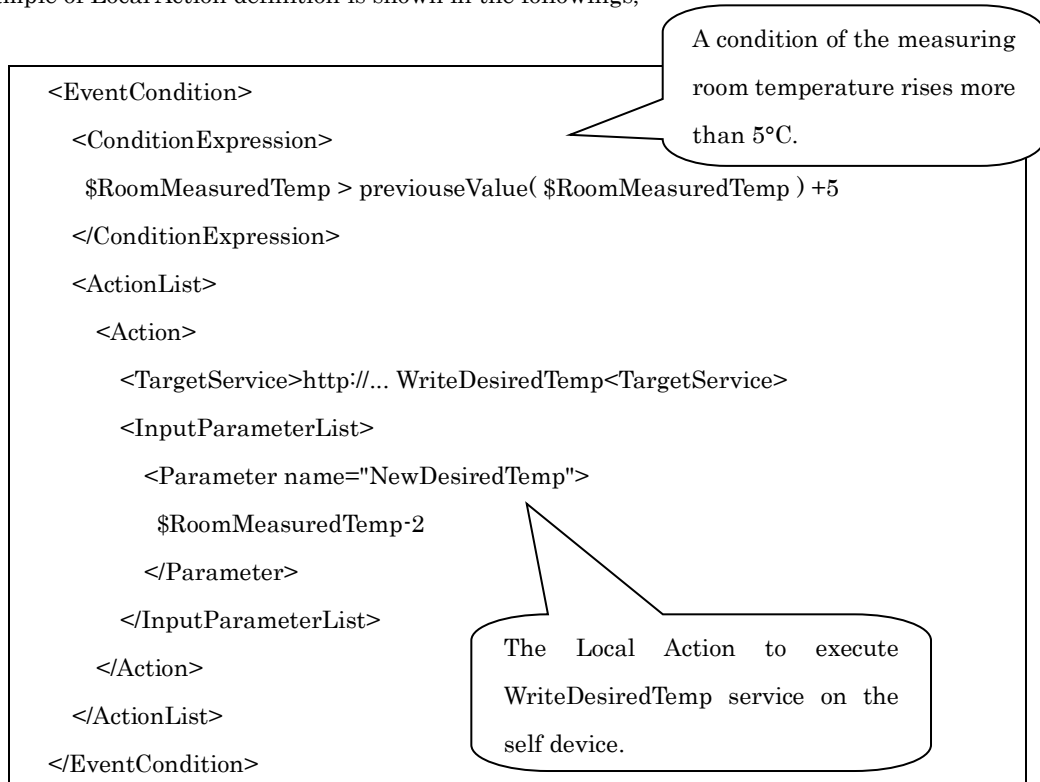

Figure. E-4 Local Action for air-conditioner

The example of Local Action definition is shown in the followings,



PUCC Device and Service Metadata Template

Remote Action executes the service defined in the metadata of the external device when the Event condition is satisfied.

Service, Input parameters for Service, and the target Device's Node_ID and Device_ID SHOULD be described in the Action Definition.

Example. 4(例 4) When the door is unlocked, the light should be turned on. Also, when the door is locked, the light should be turned off.

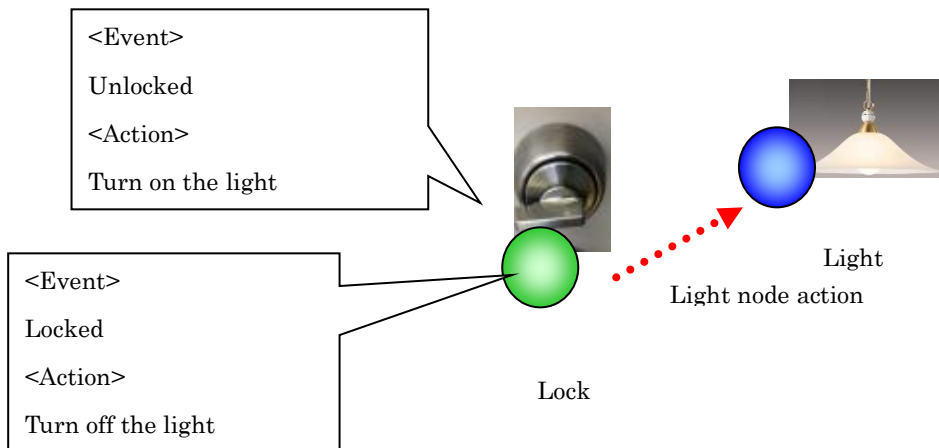

Figure. E-5 Remote Action for Light Device

The Remote Action shown in Figure E-5 is described in the following example.

```

<EventCondition>
  <ConditionExpression>
    $Lockup1Status.equals("UnLocked")
  </ConditionExpression>
  <ActionList>
    <Action>
      <TargetNode>Light</TargetNode>
      <TargetDevice>Light:1</TargetDevice>
      <TargetService>http://... SetOperationStatus<TargetService>
      <InputParameterList>
        <Parameter name="NewOperationStatus">ON</Parameter>
      </InputParameterList>
    </Action>
  </ActionList>
  
```

A condition of key unlocked

The Action to execute SetOperationStatus(ON) service of the Light Device.

PUCC Device and Service Metadata Template

```

</EventCondition>
<EventCondition>
  <ConditionExpression>
    $Lockup1Status.equals("Locked")
  </ConditionExpression>
  <ActionList>
    <Action>
      <TargetNode>Light</TargetNode>
      <TargetDevice>Light:1</TargetDevice>
      <TargetService>http://... SetOperationStatus</TargetService>
      <InputParameterList>
        <Parameter name="NewOperationStatus">OFF</Parameter>
      </InputParameterList>
    </Action>
  </ActionList>
</EventCondition>

```

A condition of Key locked

The Action to execute SetOperationStatus(OFF) service of the Light Device.

Example. 5 Synchronize the Light and Air-conditioner power status.

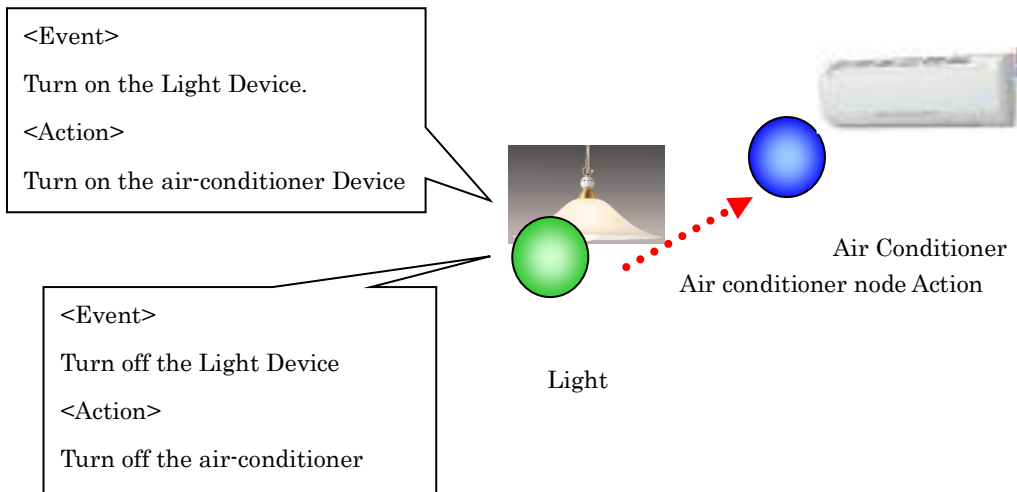

Figure. E-6 Remote Action for Light Device

PUCC Device and Service Metadata Template

The example of Remote Action definition is shown in the followings,

Light Device Metadata

```

<Device type="http:... Light" id="Light:1" name="Light Device in Living Room">
  :
  <StateVariableList>
  :
  <StateVariable name="OperationStatus" datatype="string">
    <AllowedValueList>
      <AllowedValue>ON</AllowedValue>
      <AllowedValue>OFF</AllowedValue>
    </AllowedValueList>
  </StateVariable>
  :
</StateVariableList>
  :
  <EventCondition>
  <ConditionExpression>
    $OperationStatus != previousValue( $OperationStatus )
  </ConditionExpression>
  <ActionList>
  <Action>
    <TargetNode>Aircon</TargetNode>
    <TargetDevice>Aircon:1</TargetDevice>
    <TargetService>http://... SetOperationStatus<TargetService>
    <InputParameterList>
      <Parameter name="NewOperationStatus">
        $OperationStatus
      </Parameter>
    </InputParameterList>
  </Action>
  </ActionList>
</EventCondition>
  
```

“OperationStatus” represents the Power status

A condition for Power status

The Action to execute SetOperationStatus service of the air-conditioner in accordance with Light power status.

PUCC Device and Service Metadata Template

Air-conditioner Metadata

```
<Device type="http://... Aircon" id="Aircon:1" name=""Living_room_air-conditioner">
:
<ServiceList>
  <Service type="http:// .../SetOperationStatus" name="SetOperationStatus">
    <InputParameterList>
      <Parameter name="NewOperationStatus" .... />
    </InputParameterList>
    <OutputParameterList/>
  </Service>
:
</ServiceList>
:
```

The Action to execute SetOperationStatus service with NewOperationStatus as an input parameter.

PUCC Device and Service Metadata Template

Appendix F. Metadata Schema

```

<?xml version="1.0" encoding="UTF-8"?>
<xsd:schema xmlns:xsd="http://www.w3.org/2001/XMLSchema">

  <xsd:annotation>
    <xsd:documentation>Device Difinition</xsd:documentation>
  </xsd:annotation>
  <xsd:element name="Device">
    <xsd:complexType>
      <xsd:attribute name="type" type="xsd:anyURI" use="required"/>
      <xsd:attribute name="id" type="xsd:string" use="required"/>
      <xsd:attribute name="name" type="xsd:string" use="required"/>
      <xsd:element ref="Specification" minOccurs="1" maxOccurs="1" use="required"/>
      <xsd:element ref="StateVariableList" minOccurs="1" maxOccurs="1" use="required"/>
      <xsd:element ref="ServiceList" minOccurs="1" maxOccurs="1" use="required"/>
      <xsd:element ref="EventConditionList" minOccurs="0" maxOccurs="1" use="optional"/>
      <xsd:element ref="PrimitiveDeviceList" minOccurs="0" maxOccurs="1" use="optional"/>
    </xsd:complexType>
  </xsd:element>

  <xsd:annotation>
    <xsd:documentation>Specification Difinition</xsd:documentation>
  </xsd:annotation>
  <xsd:element name="Specification">
    <xsd:complexType>
      <xsd:element name="Manufacture" type="xsd:string" minOccurs="0" maxOccurs="1" use="optional"/>
      <xsd:element name="ManufactureDate" type="xsd:date" minOccurs="0" maxOccurs="1" use="optional"/>
      <xsd:element name="ModelDescription" type="xsd:string" minOccurs="0" maxOccurs="1" use="optional"/>
      <xsd:element name="ModelName" type="xsd:string" minOccurs="0" maxOccurs="1" use="optional"/>
      <xsd:element name="ModelNumber" type="xsd:string" minOccurs="0" maxOccurs="1" use="optional"/>
      <xsd:element name="SerialNumber" type="xsd:string" minOccurs="0" maxOccurs="1" use="optional"/>
      <xsd:element name="UDN" type="xsd:UUID" minOccurs="0" maxOccurs="1" use="optional"/>
      <xsd:element name="UPC" type="xsd:string" minOccurs="0" maxOccurs="1" use="optional"/>
    </xsd:complexType>
  </xsd:element>

```

PUCC Device and Service Metadata Template

```

<xsd:element ref="IconList" type="xsd:string" minOccurs="0" maxOccurs="1" use="optional"/>
</xsd:complexType>
<xsd:simpleType name="UUID">
  <xsd:restriction base="xs:string">
    <xsd:pattern value="(urn:uuid:)?[0-9a-fA-F]{8}-[0-9a-fA-F]{4}-[0-9a-fA-F]{4}-[0-9a-fA-F]{4}-[0-9a-fA-F]{12}|
    \{[0-9a-fA-F]{8}-[0-9a-fA-F]{4}-[0-9a-fA-F]{4}-[0-9a-fA-F]{4}-[0-9a-fA-F]{12}\}"/>
  </xsd:restriction>
</xsd:simpleType>
</xsd:element>

<xsd:element name="IconList">
  <xsd:complexType>
    <xsd:element name="Url" type="xsd:anyURI" minOccurs="1" maxOccurs="unbound" use="required"/>
  </xsd:complexType>
</xsd:element>

<xsd:annotation>
  <xsd:documentation>State Variable Definition</xsd:documentation>
</xsd:annotation>

<xsd:element name="StateVariableList">
  <xsd:complexType>
    <xsd:element ref="StateVariable" minOccurs="1" maxOccurs="unbound" use="required"/>
  </xsd:complexType>
</xsd:element>

<xsd:element name="StateVariable">
  <xsd:complexType>
    <xsd:attribute name="name" type="xsd:string" minOccurs="1" maxOccurs="1" use="required"/>
    <xsd:attribute name="datatype" minOccurs="1" maxOccurs="1" use="required"/>
    <xsd:attribute name="unit" minOccurs="0" maxOccurs="1" use="optional"/>
    <xsd:attribute name="sendEvents" minOccurs="0" maxOccurs="1" use="optional"/>
    <xsd:element name="DefaultValue" type="xsd:anyType" minOccurs="0" maxOccurs="1" use="optional"/>
    <xsd:choice minOccurs="1" maxOccurs="1">
      <xsd:element ref="AllowedValueList"/>
    </xsd:choice>
  </xsd:complexType>
</xsd:element>

```

PUCC Device and Service Metadata Template

```
<xsd:element ref="AllowedValueRange"/>
</xsd:choice>
</xsd:complexType>
</xsd:element>

<xsd:element name="AllowedValueList">
  <xsd:complexType>
    <xsd:element name="AllowedValue" type="xsd:anyType" minOccurs="1" maxOccurs="unbound" use="required"/>
  </xsd:complexType>
</xsd:element>

<xsd:element name="AllowedValueRange">
  <xsd:complexType>
    <xsd:choice minOccurs="1" maxOccurs="1">
      <xsd:element name="Minimum" type="xsd:integer"/>
      <xsd:element name="Minimum" type="xsd:float"/>
      <xsd:element name="Minimum" type="xsd:double"/>
    </xsd:choice>
    <xsd:choice minOccurs="1" maxOccurs="1">
      <xsd:element name="Maximum" type="xsd:integer"/>
      <xsd:element name="Maximum" type="xsd:float"/>
      <xsd:element name="Maximum" type="xsd:double"/>
    </xsd:choice>
    <xsd:choice minOccurs="0" maxOccurs="1">
      <xsd:element name="Step" type="xsd:integer"/>
      <xsd:element name="Step" type="xsd:float"/>
      <xsd:element name="Step" type="xsd:double"/>
    </xsd:choice>
  </xsd:complexType>
</xsd:element>

<xsd:annotation>
  <xsd:documentation>Service Definition</xsd:documentation>
</xsd:annotation>
```

PUCC Device and Service Metadata Template

```
<xsd:element name="ServiceList">
  <xsd:complexType>
    <xsd:element ref="Service" minOccurs="1" maxOccurs="unbound" use="required"/>
  </xsd:complexType>
</xsd:element>

<xsd:element name="Service">
  <xsd:complexType>
    <xsd:attribute name="type" type="xsd:anyURI" use="required"/>
    <xsd:attribute name="name" type="string" use="required"/>
    <xsd:element ref="InputParameterList" minOccurs="0" maxOccurs="1" use="optional"/>
    <xsd:element ref="OutputParameterList" minOccurs="0" maxOccurs="1" use="optional"/>
  </xsd:complexType>
</xsd:element>

<xsd:element name="InputParameterList">
  <xsd:complexType>
    <xsd:element ref="Parameter" minOccurs="0" maxOccurs="unbounded" use="optional"/>
  </xsd:complexType>
</xsd:element>

<xsd:element name="OutputParameterList">
  <xsd:complexType>
    <xsd:element ref="Parameter" minOccurs="0" maxOccurs="unbounded" use="optional"/>
  </xsd:complexType>
</xsd:element>

<xsd:element name="Parameter">
  <xsd:complexType>
    <xsd:attribute name="name" type="xsd:string"/>
    <xsd:attribute name="datatype" type="xsd:anyType"/>
    <xsd:attribute name="relatedStateVariable" type="xsd:string"/>
    <xsd:element name="DefaultValue" type="xsd:anyType" minOccurs="0" maxOccurs="1" use="optional"/>
    <xsd:choice minOccurs="1" maxOccurs="1">
```

PUCC Device and Service Metadata Template

```
<xsd:element ref="AllowedValueList"/>
<xsd:element ref="AllowedValueRange"/>
</xsd:choice>
</xsd:complexType>
</xsd:element>

<xsd:annotation>
<xsd:documentation>Event Condition Difinition</xsd:documentation>
</xsd:annotation>
<xsd:element name="EventConditionList">
<xsd:complexType>
<xsd:element ref="EventCondition" minOccurs="1" maxOccurs="unbound" use="required"/>
</xsd:complexType>
</xsd:element>

<xsd:element name="EventCondition">
<xsd:complexType>
<xsd:attribute name="id" type="xsd:string" minOccurs="1" maxOccurs="1" use="required"/>
<xsd:element ref="ConditionExpression" minOccurs="1" maxOccurs="1" use="required"/>
<xsd:element ref="NotificationVariableList" minOccurs="0" maxOccurs="1" use="optional"/>
<xsd:element ref="ActionList" minOccurs="0" maxOccurs="1" use="optional"/>
</xsd:complexType>
</xsd:element>

<xsd:element name="ConditionExpression" type="xsd:string">
<xsd:complexType>
<xsd:attribute name="format" type="xsd:string" minOccurs="0" maxOccurs="1" use="optional"/>
<xsd:attribute name="period" type="xsd:string" minOccurs="0" maxOccurs="1" use="optional"/>
<xsd:attribute name="time" type="xsd:dateTime" minOccurs="0" maxOccurs="1" use="optional"/>
</xsd:complexType>
</xsd:element>

<xsd:element name="NotificationVariableList">
<xsd:complexType>
```

PUCC Device and Service Metadata Template

```
<xsd:element ref="StateVariable" minOccurs="1" maxOccurs="unbound" use="required"/>
</xsd:complexType>
</xsd:element>

<xsd:element name="ActionList">
  <xsd:complexType>
    <xsd:element ref="Action" minOccurs="1" maxOccurs="unbound" use="required"/>
  </xsd:complexType>
</xsd:element>

<xsd:element name="Action">
  <xsd:complexType>
    <xsd:choice minOccurs="1" maxOccurs="1">
      <xsd:element name="TargetNode" type="xsd:string"/>
      <xsd:element name="TargetDevice" type="xsd:string"/>
    </xsd:choice>
    <xsd:element name="TargetService" type="xsd:anyURI" minOccurs="1" maxOccurs="1" use="required"/>
  </xsd:complexType>
</xsd:element>

<xsd:annotation>
  <xsd:documentation>Primitive Device Difinition</xsd:documentation>
</xsd:annotation>

<xsd:element name="PrimitiveDeviceList">
  <xsd:complexType>
    <xsd:element ref="PrimitiveDevice" minOccurs="1" maxOccurs="unbound" use="required"/>
  </xsd:complexType>
</xsd:element>

<xsd:element name="PrimitiveDevice">
  <xsd:complexType>
    <xsd:attribute name="type" type="xsd:anyURI" use="required"/>
    <xsd:attribute name="id" type="xsd:string" use="required"/>
    <xsd:attribute name="name" type="xsd:string" use="required"/>
  </xsd:complexType>
</xsd:element>
```

PUCC Device and Service Metadata Template

```
<xsd:element ref="Specification" minOccurs="1" maxOccurs="1" use="required"/>
<xsd:element ref="StateVariableList" minOccurs="1" maxOccurs="1" use="required"/>
<xsd:element ref="ServiceList" minOccurs="1" maxOccurs="1" use="required"/>
<xsd:element ref="EventConditionList" minOccurs="0" maxOccurs="1" use="optional"/>
<xsd:element ref="PrimitiveDeviceList" minOccurs="0" maxOccurs="1" use="optional"/>
</xsd:complexType>
</xsd:element>

</xsd:schema>
```

Appendix G. Version History

Document number	Date	Note
PUCC Device and Service Metadata Template For Release 3	22 Mar, 2012	Version 3.0
Appendix F. Metadata Schema is added.	17 Oct. 2020	Version 3.1